

PAPA DOO RUN RUN

2006 TECHNICAL & PERFORMANCE RIDER

(6)

P O BOX 255 ♦ CUPERTINO, CA 95015-0255 ♦ (408) 257-2533 ♦ FAX (408) 252-8938
web site: www.papadoo.com ♦ email: papadoo@aol.com

All terms and provisions contained herein, are integral and binding parts of the face of the agreement. All staging and equipment is to be provided, as specified. DO NOT MAKE ANY SUBSTITUTIONS WITHOUT THE EXPRESS CONSENT OF PAPA DOO RUN RUN. Should there be a disparity between PAPA DOO RUN RUN's technical rider, and that of another entity (i.e. other act, venue, sound company, etc.), PAPA's rider will take precedence.

A) STAGE & POWER: The stage is to be a sturdy, single level platform, (20'D x 40'W x 2'H optimum - 16'D x 32'W x 1.5'H minimum). A carpeted drum riser (8'x8'x2') is recommended at center stage. If PAPA is sharing the stage with another act, and the keyboards need to be moved, then a 6'x 6'x 12" rolling riser is also required. Seven cloth towels, a case (24-16.9oz (500ml) bottles) of Crystal Geyser, Calistoga or other non-carbonated water is required on stage at load-in.

The stage is to be set, in place and free of encumbrances when the crew arrives for load-in. PAPA's band gear placement will take first priority over other acts, decor, podiums, etc. Any delay in starting performance due to incomplete staging is purchaser's sole responsibility. If there is to be a dance floor, it is to be centered, directly in front of the stage, with no obstruction between the dance floor and stage.

Storage for equipment cases is required. It should be a 15' x 15' area, adjacent to the stage and out of sight of the audience.

If stage is outside, purchaser shall provide plastic covers to cover all equipment and stored cases. Weather damage to equipment is purchaser's sole responsibility.

PAPA's band gear will require a POWER DROP BOX supplying at least three (3) 20 AMP circuits @ 115V AC each. PAPA's sound system and lights will require an additional five (5) 20 AMP circuits @ 115V AC - 8 total outlets on dedicated circuits. Catered equipment (sound system, and lights) may require more power. Check with the rental company(s) for their electrical requirements. Power failure, delays in performance, and/or damage to equipment or personnel is purchaser's sole responsibility.

B) LIGHTS: 4 light trees (or a front and back truss) are required with at least 8 multi-colored par 64 (or larger) spots per tree (32 instruments total). Suggested colors include: red, pink, violet, turquoise, yellow, and blue. Dimmer board or controller is to be positioned at the sound console. Smoke or light fog is recommended. NO LESS THAN ONE-HALF OF THE CANS SHOULD BE IN FRONT OF THE BAND, PROPERLY FOCUSED ON EACH INDIVIDUAL IN THE BAND.

An experienced L.D. is required.

C) SOUND SYSTEM: A quality sound system is critical to PAPA's performance. PAPA requires a sound system consisting of a minimum of the following:

- 1 - 32 channel mixing board, with 3 band eq., 2 effects sends, 4 sub-mixes, and a stereo house mix. House board is to be positioned in line with center stage, at least 75' but not more than 150' from the front of the stage. (A knowledgeable operator should be available to set up, and dial in the board, however, PAPA's tech will mix PAPA's show).
- 1 - 32 channel snake. Snake must be covered with a runner or taped securely to the floor.
- 2 - 3-way speaker system (including 18" subs) suitable for venue size (EAW, TURBOSOUND, JBL preferred), with appropriate cabling, power amps, equalizers, and crossovers.
- 2 - Yamaha SPX 900/90 (or equivalent) digital effects processors.
(1 for reverb on snare and toms - small room 2.2 sec.).
(1 for echo on vocals - stereo echo 220 ms @ 30% left / 250 ms @ 30% right).
- 1 - Quad noise gate (Gatex preferred) (to gate undesirable ring from drums).
- 1 - Dual compressor/limiter (compression on stereo house mix) (DBX preferred.)
- 3 - Direct boxes (bass and keyboards L & R).
- 18 - Microphones and stands as per attached MICROPHONE INPUT SHEET.
- 4 - 6 outlet power strips supplying 20 amps @ 60 cycle/115V AC for stage gear.
- 1 - Cassette deck or CD player for pre-show and break music. A selection of music appropriate to the theme of event is required.

D) MONITOR SYSTEM: PAPA DOO RUN RUN features 5 part harmony and requires a high quality stage monitor system. 8 mixes into 10 wedges are required. See stage plot for monitor placement.

- 1 - 32 channel mixing board (for monitors) with at least 8 mixes. Monitor board is to be positioned at stage right. An experienced operator should be available to mix PAPA's monitors during the sound check and show.
- 10 - 2 way floor monitors, each with at least 1-15" or 2-12" speakers, and a high frequency horn (EAW, TURBOSOUND, or JBL preferred).
- 8 - 1/3 octave graphic equalizers, 8 amplifiers with appropriate cabling.

*(NOTE: 2-JC120 or 2-FenderTwin guitar amps may substitute for keyboard L/R mon mixes 7 & 8).

IMPORTANT! SOUND SYSTEM AND MONITORS ARE TO BE UP, RUNG OUT, AND RUNNING WHEN THE BAND ARRIVES FOR SOUND CHECK.

Please have the sound system provider call Don Zirilli @ (408) 257-2533 to confirm these requirements.

IF STAGE GEAR IS A PROVISION OF THE AGREEMENT, THE FOLLOWING IS REQUIRED:

E) STAGE GEAR: We realize that the exact gear specified may not be available at all locations, however, we have tried to be as generic as possible, requiring industry standard stage gear. Please make NO substitutions without PAPA's consent.

DRUMS

TO BE SET UP WITH SEAT ON AMP LINE.

1- 6 piece drum kit (Yamaha or Pearl) consisting of the following:

- 1 - 22" bass drum;
- 2 - 5.5" x 14" snare drums;
- 1 - 10" rack power tom (on separate tall stand);
- 1 - 12" rack power tom (double mount on bass drum);
- 1 - 13" rack power tom (double mount on bass drum);
- 1 - 16" floor tom;
- 1 - 14" high hat (2 cymbals, heavy duty stand and pedal);
- 1 - 12" splash cymbal;
- 1 - 16" crash cymbal;
- 1 - 18" crash cymbal;
- 1 - 20" medium ride cymbal;
- 1 - Adjustable throne;
- 1 - Yamaha or Pearl double bass drum pedal.

All appropriate cymbal boom stands, pedals, and hardware. All heads must be in excellent condition.

KEYBOARDS

- 2 - Yamaha DX-7 (or DX-7II FD) synthesizers;
- 1 - Yamaha P-200 (2nd choice: Kurzweil PC88 digital stage piano; 3rd choice Roland RD 600).

PAPA will bring keyboard stand and mixer. Stereo keyboard mix goes to monitor mixes 6(L) and 7(R).

GUITAR AMPS

- 1 - Bass amp (Gallien Krueger 800 RB or Ampeg SVT-II) with 1x15" **AND** 4x10" spkrs.
 - 2 - Fender Twins guitar amp ("Twin Amp" 100 watt+ w/ channel switching and pedal).
 - 1 - Roland JC-120 (100 watt+ w/ channel switching and pedal).
 - 4 - Guitar stands.
- *(NOTE: 2-JC120 or 2-FenderTwin guitar amps may substitute for keyboard L/R mon mixes 7 & 8).

PAPA WILL BRING:

3 guitars, 1 bass, synth modules, keyboard mixer and effects, pedals, wires, keyboard stand, keyboard seat, drum sticks, and guitar tuner (9 - 10" x 24" x 60" flight cases).

Please have the stage gear provider call Don Zirilli @ (408) 257-2533 , to confirm these requirements.

MICROPHONE INPUTS

| CHANNEL / POSITION | STAND | MICROPHONE (1st, 2nd, 3rd choices) | SUBMIX / PAN (1 vocals, 2 drums L, 3 drums R 4 instruments L, 5 instruments R) | |
|---------------------------|--|--|---|----------------|
| 1. | Keyboard vocal (Don) | Boom | Beta 58, SM 58, SM 57 | 1 |
| 2. | Bass vocal (Jim) | Boom | Beta 58, SM 58, SM 57 | 1 |
| 3. | Rhythm Guitar vocal (Jeff) | Boom | Beta 58, SM 58, SM 57 | 1 |
| 4. | Rhythm Guitar vocal (Adrian) | Boom | Beta 58, SM 58, SM 57 | 1 |
| 5. | Lead Guitar vocal (Bob) | Boom | Beta 58, SM 58, SM 57 | 1 |
| 6. | Drum vocal (Bo) | Boom | Beta 58, SM 58, SM 57 | 1 |
| 7. | Keyboards (pan LEFT) | - | DI from keyboard mixer | 4 hard left |
| 8. | Keyboards (pan RIGHT) | - | DI from keyboard mixer | 5 hard right |
| 9. | Bass Guitar | - | DI | 4/5 center |
| 10. | Rhythm Guitar 1 (Jeff) | Boom | SM 57, SM 58 | 4/5 9 o'clock |
| 11. | Rhythm Guitar 2 (Adrian) | Boom | SM 57, SM 58 | 4/5 3 o'clock |
| 12. | Lead Guitar | Boom | SM 57, SM 58 | 4/5 center |
| 13. | Kick Drum | Desk boom | Senn 421, RE 20, AKG D112 | 2/3 center |
| 14. | Snare | Boom | CS 15, SM 57 | 2/3 center |
| 15. | Hi Rack Tom | Boom or clip | Senn 421, D112, SM 57 | 2/3 3 o'clock |
| 16. | Mid Rack Tom | Boom or clip | Senn 421, D112, SM 57 | 2/3 1 o'clock |
| 17. | Low Rack Tom | Boom or clip | Senn 421, D112, SM 57 | 2/3 11 o'clock |
| 18. | Floor Tom | Boom or clip | Senn 421, D112, SM 57 | 2/3 9 o'clock |
| 19. | Hi Hat | Boom | SM 81, ATM 405, SM 57 | 2/3 center |
| 20. | Overhead (Left) | Boom | SM 81, ATM 4051, SM 57 | 2 hard left |
| 21. | Overhead (Right) | Boom | SM 81, ATM 4051, SM 57 | 3 hard right |
| 22-28. | Open. Use for off stage announce, CD, etc. | | | |
| 29. | EFX return (LEFT ECHO 220 ms @ 30%) | Pan hard left. | | |
| 30. | EFX return (RIGHT ECHO 250 ms @ 30%) | Pan hard right. | | |
| 31. | EFX return (LEFT REVERB small room) | Pan hard left. | | |
| 32. | EFX return (RIGHT REVERB) | Pan hard right. | | |

MONITOR MIXES (from separate board positioned at stage right)

| | | | |
|--------|---------------|---------|---|
| MIX 1. | (KEYBOARD) | Don: | All vocals (100% Don, 90% others), all 3 guitars, kick, snare, hat. |
| MIX 2. | (BASS) | Jim: | All vocals (100% Jim, 90% others except keybd vocal 0%), kick, snare. |
| MIX 3. | (RTHM GUIT 1) | Jeff: | All vocals (100% Jeff, 90% others, keyboards). |
| MIX 4. | (RTHM GUIT) | Adrian: | All vocals (100% Adrian, 90% others), keyboards. |
| MIX 5. | (LEAD GUIT) | Bob: | All vocals (100% Bob, 70% others), keyboards, snare. |
| MIX 6. | (DRUMS) | Bo: | All vocals, slight keyboards & guitars, all drums, heavy kick. |
| MIX 7. | (L KEYBOARDS) | | Only left side of keyboard mix. |
| MIX 8. | (R KEYBOARDS) | | Only right side of keyboard mix. |

*(NOTE: 2-JC120 or 2-FenderTwin guitar amps may substitute for keyboard L/R mon mixes 7 & 8).

HOUSE MIX

40% instruments, 60% vocals, Heavy kick & snare, with lots of high end (4K), and low end (100Hz) on kick.
 Small hall reverb on snare and toms.
 Digital delay (stereo echo) on all vocals (L: 220 ms @ 30% / R: 250 ms @ 30%)

CONTACT: DON ZIRILLI / office: 408-257-2533 / fax: 408-252-8938 / e-mail: papadoo@aol.com

REV 1-06

MIC. INPUTS
CHANNEL / POSITION

1. KYBD VOCAL DON
2. BASS VOCAL JIM
3. R. GUIT VOCAL JEFF
4. R. GUIT VOCAL ADRIAN
5. L. GUIT VOCAL BOBBY
6. DRUM VOCAL BO
7. KYBD LEFT (DI)
8. KYBD RIGHT (DI)
9. BASS (DI)
10. RYTH GUITAR 1
- *11. RYTH GUITAR 2
12. LEAD GUITAR
13. KICK
14. SNARE
15. HI RACK TOM
16. MID RACK TOM
17. LOW RACK TOM
18. FLOOR TOM
19. HAT
20. OVERHEAD (L)
21. OVERHEAD (R)

8 MONITOR MIXES
WITH 10 WEDGES

STAGE SIZE: 20' X 40'
6' x 8' x 18" DRUM RISER.

AT FULLY CATERED EVENTS
(OUTSIDE OF CA, AZ & NV)
PAPA WILL BRING:

4 GUITARS
KEYBOARD MIXER RACK
KEYBOARD STAND & SEAT
CABLES, PEDALS, EFX, AND
DRUM STICKS

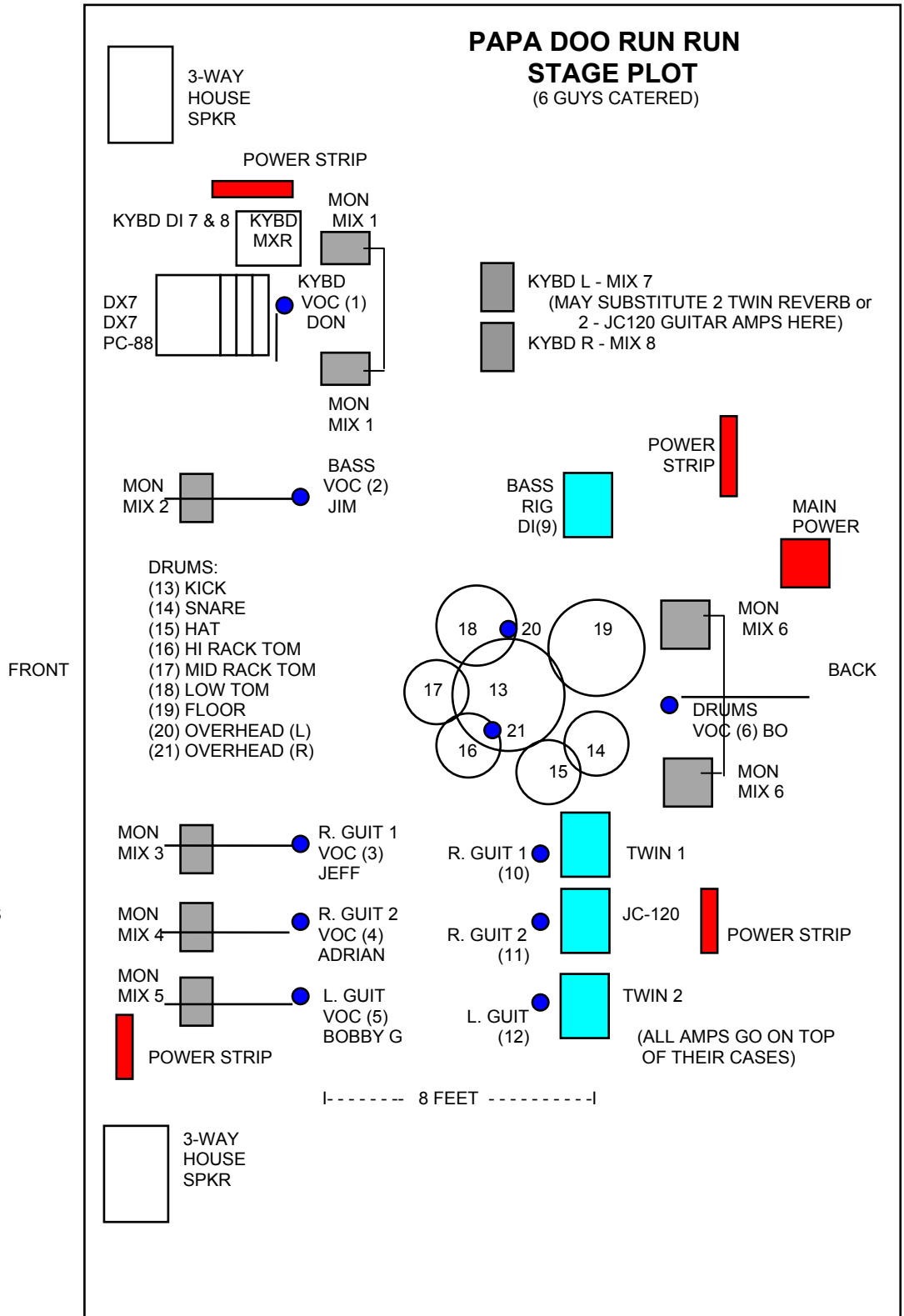

FOR MORE INFORMATION CALL: DON ZIRILLI (408) 257-2533

PAPA DOO RUN RUN
SYNOPSIS OF MINIMUM RENTAL REQUIREMENTS
FOR MORE INFORMATION CALL: DON ZIRILLI (408) 257-2533
OR VISIT PAPA's WEB SITE www.papadoo.com and click on RIDER.

PA SYSTEM -----

- 1 32 ch mixing board w/ 2 fx send (postfade), 4 stereo submixes, and a stereo house mix.
 - 1 32 ch snake, (covered w/ runner stage to board).
 - 2 3-way speaker systems, suitable for venue size, including:
 - Amplifiers,
 - Equalizers,
 - Electronic crossovers (or processors).
 - 1 House drive rack with:
 - 2 SPX-90 (or equivalent) effects processors.
 - 1 quad noise gate.
 - 1 dual compressor/limiter.
 - 18 Microphones:
 - 6 Shure Beta 58 (vocals).
 - 7 Shure SM 57 (guitars & drums).
 - 5 Senn 421 or AKG D112 (kick & toms).
 - 3 Direct boxes (bass & keyboards L/R).
 - 1 CD player w/ a selection of CD's (pop, oldies, dinner music).
 - 17 Boom mic. stands. (may substitute mic clips for tom mics)
 - 1 Desk mic. stand (kick).
- ALL APPROPRIATE WIRES AND CABLES

MONITORS -----

- 1 32 ch monitor mixing board w/ at least 8 monitor mixes.
 - 1 32 ch splitter (monitor/house).
 - 10 2-way floor monitor speakers (1-15" and horn or 2-12" and horn).
 - 8 500 watt power amplifiers (or 4-stereo 500w per side amplifiers), with appropriate cabling.
 - 8 1/3 octave graphic equalizers.
- (NOTE: 2 Roland JC120 guitar amps may substitute for keyboard L/R monitor mixes 7 & 8).

BAND GEAR -----

Drums (6 piece kit - Yamaha or Pearl)

- bass drum 22"
- snare 5.5" x 14"
- rack toms: 10", 12", 13"
- floor tom 16"
- cymbals: 14" hat, 12" splash, 16" crash, 18" crash, 20" ride.
- adjustable throne
- all pedals, stands, and hardware.

Keyboards

- 1 - Yamaha DX-7 (or DX-7II FD) synthesizer;
- 1 - Hammond XB2 or KX-2 (single keyboard portable) organ (may substitute an additional DX7).
- 1 - Korg SG1 (2nd choice: Kurzweil PC88 digital stage piano; 3rd choice Roland RD 500).

PAPA will bring keyboard stand and keyboard mixer.

Amplifiers

- 2 - Fender "TWIN AMP" guitar amps (100 watt min. w/ channel switching and pedals).
- 1 - Roland JC-120 guitar amps (100 watt min. w/ channel switching and pedals).
- 1 Gallien Krueger 800 RB bass amp (or Ampeg SVT-II) with 1-15" **AND** 4-10" speakers.

LIGHTS & MISC. -----

- 4 Light trees (or a front/rear truss) with at least 8 par 64 lamps/tree (32 lamps total) w/controller, cables, and colored gels: red, yellow, aqua, pink, blue, green.
- 4 6 outlet power strips.
- 4 50' extension cords.
- 4 guitar stands.

PAPA DOO RUN RUN

P O BOX 255 ♦ CUPERTINO, CA 95015-0255 ♦ (408) 257-2533 ♦ FAX (408) 252-8938

web site: www.papadoo.com ♦ email: papadoo@aol.com

2006 PERFORMANCE RIDER

All terms and provisions contained herein, are integral and binding parts of the face of the agreement.

A) ADVERTISING: PAPA DOO RUN RUN's name and/or likeness will appear in all ads connected with the event(s) named in the agreement, in the first position and 100% size.

B) TRANSPORTATION / ROOMS: *If* AIR TRANSPORTATION is a provision of the agreement, unless otherwise indicated, PAPA will make their own travel arrangements and upon approval will invoice purchaser for such travel. If purchaser is to provide tickets, flights must be on UNITED, AMERICAN, or DELTA AIRLINES ONLY. Costs will include all taxes and fees, and may include up to \$400 in excess baggage charges. Flights with total travel time over 5 hr. duration must be First or Business Class. Flights under 5 hrs. must be at least Full Coach class. Coach tickets must be upgradeable and fully refundable without penalty. All mileage points accrued will be the property of the individual flyers. All flights must be to and from locations and at times convenient to PAPA.

If HOTEL ROOMS are a provision of the agreement, they must be prepaid (including all taxes, gratuities, parking, and related fees), located at the venue hotel, and reserved under the individual names of the band and crew. Early check-in and/or late check out may be required. Non-smoking, king single rooms should be reserved for the following:

Don Zirilli, Jim Rush, Bob Gothar, Adrian Baker, Edward Fox, Jeffrey Foskett.
Al Nassar, and Bob Busch. (These 2 names will inter-change from time to time).

Per Diem. For events requiring a 2 or more night stay, PAPA requires Per Diem of not less than \$50 per man per day. In hotels which offer it, a "Meal Plan" of not less than 2 meals per day may be in lieu of Per Diem.

If GROUND TRANSPORTATION is a provision of the agreement, it must be either a 12-15 passenger air-conditioned private van, or 2 mini vans, or 2 limos, with English speaking drivers. Said transportation will display a sign denoting "PAPA DOO RUN RUN", and will meet band members and crew at the baggage claim for their particular flights. If, for some reason, performance venue and hotel are not one and the same, then ground transportation must be provided between the two, at times convenient to PAPA.

If reimbursement for plane tickets, hotel, ground transportation, meals, or other reimbursable expenses is indicated, it will be immediate upon receipt of invoice. Reimbursement and/or costs of above are not subject to any agency commissions.

C) ACCESS TO VENUE: A clear access to the load-in area is required at least FOUR (4) hours prior to the time the audience is to be admitted. If catered equipment is indicated, check with rental companies for required access time. Delays in starting performance due to failure to provide clear access is purchaser's sole responsibility.

If load-in area is a soft deck (gravel, lawn, sand, etc.), purchaser will provide a plywood walkway 1" thick x 36" wide the entire length of such soft deck. Lights in the loading and stage areas shall remain ON until load-in/out is complete.

Purchaser will provide parking, as close to the stage as possible, for the equipment truck (30'L x 8'W x 12'H), and up to five additional vehicles at no cost to PAPA.

Loaders, technicians, and sound/light personnel will work under the direction of PAPA's crew chief. Lack of cooperation, and nonprofessional attitudes, will not be tolerated. Purchaser is responsible for procurement of any required union loaders, and/or technicians, and their compensation due, when required.

PAPA and their accompanying personnel shall be allowed COMPLETE ACCESS to stage, backstage, and performance areas. If necessary, purchaser will provide back stage passes, badges, or other identification to allow access.

D) DRESSING ROOM: Purchaser will provide a separate private dressing room (or motor home), with electrical outlets, and comfortable seating for 10 people, near the stage. It should be made available from load-in thru load-out, and be a no smoking area. In most hotel situations, an additional sleeping (or hospitality) room, or nearby meeting room (preferably with bathroom / shower facilities) will serve as a dressing room.

E) REFRESHMENTS: Purchaser will provide refreshments for the band and crew (10 people total) from load-in thru load-out. At load-in: a CASE of Calistoga, Crystal Geysler, or other non-sparkling bottled water, is required at the stage. At sound check: (or two hours prior to doors opening, whichever comes first) catering is required in dressing room or other suitable area. Suggestions include: A hot meal - chicken, fish, pasta, or other low fat hot entree (no red meat please), salads, fruit, veggies, desert items, soft drinks (please include caffeine-free beverages), juices, coffee (cream & sugar), water, ice, cups, glasses, plates, and utensils. Please avoid deli-trays unless there is no other option. The band would rather have a few pizzas and a bucket of chicken than another deli tray. REFRESHMENTS ARE TO REMAIN IN THE DRESSING ROOM AREA UNTIL LOAD-OUT IS COMPLETE.

F) STAGE: The stage is to be a sturdy, single level platform, at least 20'D x 40'W x 2'H. A carpeted drum riser (8' x 8' x 2') is recommended at center stage. 10 cloth towels, and a case (12-1.5L bottles - or 24-0.5L bottles) of Calistoga, Crystal Geysler, or other non-carbonated bottled water are required on stage at load-in.

The stage is to be set, in place and free of encumbrances when the crew arrives for load-in. PAPA's band gear placement will take first priority over decor, podiums, opening acts equipment, etc. Any delay in starting performance due to incomplete staging is purchaser's sole responsibility. If there is to be a dance floor, it is to be centered, directly in front of the stage, with no obstruction (tables, decor, etc.) between stage and dance floor.

If necessary, purchaser will provide electric fans, and/or heaters on stage to assure that stage temperature does not rise above 105 degrees F nor fall below 45 degrees F. If temperature exceeds either limit, PAPA will have the option to postpone, cancel, or curtail their show, with no effect to compensation.

Storage for equipment cases is required. It should be a 15' x 15' area, near the stage and out of sight of the audience. If stage is outside, purchaser shall provide plastic covers to cover all equipment and stored cases. A roof or cover over the stage area is recommended. Weather damage to equipment and stored cases, including but not limited to rain, wind, snow, hail, and excessive heat, is purchaser's responsibility.

G) POWER REQUIREMENTS: PAPA requires a POWER DROP BOX supplying at least eight (8) 20 AMP outlets @ 115V AC each, all on separate circuits, for PAPA's exclusive use. Power failure, delays in performance, and/or damage to equipment or personnel due to faulty electricity is purchaser's sole responsibility.

H) GENERAL TERMS AND CONDITIONS:

1) COMPENSATION will be paid in U.S. dollars, in cash, or certified or institution check, payable to: PAPA DOO RUN RUN, and DELIVERED to Don Zirilli (leader- keyboardist) in a sealed envelope, at, or immediately PRIOR TO PERFORMANCE. Agency commissions (if any) will be paid within 7 days after the event, after the balance due check has cleared. Overtime compensation will be invoiced, and is due upon receipt of invoice. Overtime compensation will not be subject to any agency commissions, unless the agent is present to negotiate the additional time.

2) Please designate one person to be a liaison between band & client.

3) Please have a time schedule ready when the band arrives. Unless specified otherwise on the face of the agreement, PAPA's show will be 120 performance minutes in length (not including breaks). Recommended set lengths are: (minutes) 60/60, 30/90, 30/60/30, 40/40/40, 30/30/30/30. PAPA will not perform longer than 100 consecutive minutes (90 min. show + 10 min. encore) without an intermission. Overtime, when applicable, will be billed on a pro-rata basis, based on the performance fee on the face of the agreement.

4) NO MIMES! Mimes, jugglers, unicyclists, and other circus type acts are to be kept off the dance floor, and at least 50' from the stage during PAPA's performance. The same goes for beach balls and other flying objects. Damage to personnel, equipment, fixtures, clothing, glassware, etc. due to flying objects, is purchaser's sole responsibility. Additionally, carnival type games, Karaoke booths, noisy décor, and catering stations, etc. are to be positioned at least 100' from the stage and will not interfere with audience sightlines or ability to clearly hear the performance.

5) NO LIMBO! PAPA DOO RUN RUN will not perform for, or during a "limbo contest".

6) PAPA DOO RUN RUN is a 60's / 70's rock band and does not play "dinner " or "background" music. Please do not ask the band to play quietly as guests enter and have dinner. Unless the event is a "dinner show", PAPA will not perform while guests are still eating. Taped or CD music will be provided if requested for no additional charge. For a nominal fee, PAPA's guitarist or pianist can provide up to 1 hour of acoustic "cocktail" or "dinner" music.

7) Stage sharing: If PAPA is to share the stage with another act, DJ, awards ceremony, etc., PAPA's equipment shall have first priority in stage position, and will not be moved without PAPA's permission.

8) NO SURPRISES! Please don't surprise the band with opening acts, comedians, Elvis impersonators, or other entities which will require stage and/or PA system access. Additionally, PAPA does not make announcements during their show. Save them for intermission.

9) Preshow and intermission music, as provided by a DJ, opening act, or sound company, will not include any songs on PAPA's current play list (available on PAPA's web site (www.papadoo.com) or provided at the event). If a DJ is to be used at the event, he will be positioned off stage, or on an unused area of the stage which will not interfere with PAPA's performance. DJ will not use any of PAPA's sound equipment, speakers, wires or electricity particular to PAPA's stage, without PAPA's permission.

10) PAPA shall retain the sole, exclusive right to merchandising and the moneys derived therefrom. This includes, but is not limited to: t-shirts, records, tapes, CDs, posters, pins, hats, etc. Unless requested by purchaser, PAPA will not offer merchandising at private, or corporate events.

11) The performance will not be recorded or transmitted without the prior consent of PAPA. Purchaser has the right to videotape PAPA's performance for in-house use only. Purchaser will supply a copy of the unedited video to PAPA at no cost to PAPA.

12) Purchaser will provide adequate security for personnel, stage, back stage, and parking areas. Purchaser will not allow stage access to audience members. Purchaser is responsible for loss, or damage to equipment, personnel, or vehicles due to inadequate security, or an unruly audience. Even though PAPA carries a \$2M umbrella insurance policy, purchaser is still responsible for their own insurance coverage (liability, etc.) naming PAPA DOO RUN RUN as additional insured.

13) PAPA retains the right to add, subtract, or change band members and crew without notice.

14) Cancellation of this event due to acts of nature, illness, epidemic, death, strikes, war, transportation or venue maladies, terrorist acts or threats, or other causes will not effect any compensation due PAPA. Any "rain date" will be negotiated and written apart from this agreement. Purchaser is encouraged to secure "rain insurance" to cover such cancellation.

15) The agreement may be rescinded by either party, without cause, by submission of written notice to the other party, not less than 30 days prior to performance date. If purchaser is rescinding party, deposit (or 50% of total compensation if no deposit is indicated, whether it has been paid yet or not) will be forfeited. If PAPA is rescinding party, all moneys paid prior to the date of cancellation will be refunded. If purchaser cancels within 30 days of performance, FULL compensation, including any reimbursement due PAPA, will be due and payable on the date of such cancellation.

16) Should there be a disparity between PAPA DOO RUN RUN's performance rider or technical rider (when applicable), and that of another entity (i.e. other act, venue, sound company, producer, agent, etc.), PAPA's rider will take precedence.

17) The agreement shall be bound by the laws of California. If an attorney is retained for the purpose of collecting compensation agreed to herein, or for any other litigation concerning PAPA DOO RUN RUN and the event herein, purchaser agrees to pay for the reasonable cost of such attorney's fees.